

**IWIN** Headquarters

527, Samseong-ro, Gangnam-gu, Seoul, Korea  
Tel. 82-2-553-1795 Fax. 82-2-566-5621/ 553-1799  
URL. [www.iwin.com](http://www.iwin.com)



**INNOVATION and MAKE it HAPPEN**



This book has been made using FSC (Forest Stewardship Council) certified, eco-friendly paper to help prevent deforestation and destruction of the environment while promoting a sustainable forest management.

Date of issue 2011.9.03



**IWIN**

# The **INNOVATIVE** **VALUE** by **TECHNOLOGY**

---

Every step forward is beautiful.  
Taking a great step forward to a bigger future of Korea.  
ILJIN always strives for Innovation.

MESSAGE FROM THE CEO	06
HISTORY	08
AWARDS	09
CORPORATE CULTURE	10
INNOVATION MANAGEMENT	12
HUB UNIT BEARING	16
CHASSIS & SUSPENSION	18
POWERTRAIN	20
INDUSTRIAL BEARING	24
RESEARCH	26
CORPORATE SOCIAL RESPONSIBILITY	28
GLOBAL NETWORKS	30



**ILJIN leading  
the future  
development**

We are moving  
towards innovation

---

## MESSAGE FROM THE CEO

---

---

As a world class bearing manufacturer, ILJIN will do its best to satisfy customer needs with best quality and competitive prices.

ILJIN Group President, **Sang Il Lee**

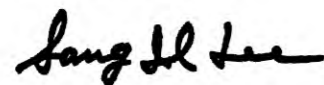

---

ILJIN was established in 1973 and has grown to be a world-class automotive component design and manufacturing company. We began our company as a forging supplier and further evolved into chassis and wheel bearing businesses.

We have now expanded into powertrain and industrial bearings to meet the needs of the global marketplace. ILJIN has expanded its R&D centers with a network connecting Korea, the U.S. and Germany. This network allows us to respond to our customers on a 24/7 real time basis.

In addition, ILJIN concentrates its competencies toward the development of environmentally friendly, lightweight, fuel efficient, and EV focused components. Currently our company is also investing in new technologies in railway bearings and aircraft landing gear bearings. We have emerged as a progressive, quick-reacting company that continuously develops diversified products for new and existing markets. ILJIN is now one of the leading bearing companies in the world – driven by our business culture of “Innovation”, “Teamwork”, with a “Make it Happen” spirit.

ILJIN strives to be a world-class company prioritizing customer satisfaction based not only on creative thinking and innovative technologies, but through the passion and challenging spirit of the entire ILJIN team.

# HISTORY

ILJIN's history began in 1973 with establishment of ILJIN Corporation. As we have grown into a world-class automotive component company for more than 50 years, ILJIN will continue to strive to be a 100 years old company.

**1973. 07.**  
Founding of ILJIN Corporation

**1978. 12.**  
Founding of ILJIN Forging  
(Currently ILJIN BEARING)

1970



1300 ton press from National, USA



Founding of BLOXWICH KOREA

1980

**1982. 08.**  
Co-Founding of BLOXWICH KOREA (Currently ILJIN GLOBAL)

**1986. 01.**  
Founding of DONG-A Industrial (Currently ILJIN Corp.)

**1994. 01.**  
ILJIN Industrial (Currently ILJIN BEARING) begins wheel bearing (2nd generation) business

**1997. 07.**  
Founding of ILJIN INDIA

1990



Begins wheel bearing business



independently developed 3rd generation wheel bearing

2000

**2000. 04.**  
ILJIN Industrial (Currently ILJIN BEARING) independently develops 3rd generation wheel bearing

**2002. 10.**  
Founding of BEIJING ILJIN

**2003. 03.**  
Founding of ILJIN USA

**2005. 01.**  
Founding of ILJIN SLOVAKIA

**2006. 11.**  
Founding of TIANJIN ILJIN

**2008. 02.**  
Founding of ILJIN AMERICA (Currently ILJIN USA SC)



Youngju factory, BEARING ART



Certification from Association of American Railroads

2010

**2010. 09.**  
Founding of ILJIN ALABAMA

**2011. 05.**  
Founding of BEARING ART (enters into industrial bearing business)

**2012. 05.**  
BEIJING ILJIN completes YANCHENG factory in (Currently JIANGSU ILJIN)

**2013. 06.**  
BEARING ART completes Youngju factory

**2014. 09.**  
ILJIN USA establishes R&D center

**2015. 06.**  
Founding of CHONGQING ILJIN

**2016. 01.**  
Founding of ILJIN GLOBAL INDIA

**2016. 01.**  
established ILJIN BEARING GmbH R&D center

**2017. 03.**  
Founding of YOKOHAMA (JAPAN) sales branch

**2017. 04.**  
Founding of PARIS (FRANCE), TURIN (ITALY) sales branch

**2018. 01.**  
BEARING ART acquires certification from the Association of American Railroads (AAR)

# AWARDS



- 1987. 03.** Awarded the Bronze Tower Order of Industrial Service Merit (for technological development)
- 1988. 11.** Awarded Export Tower of 10 Million
- 2000. 11.** Awarded the Bronze Award of New Tech Korea
- 2000. 11.** Selected as an export leading company (Ministry of Commerce, Industry and Energy)
- 2002. 05.** Awarded the Gold Tower Order of Industrial Service Merit
- 2004. 01.** Awarded Korea's Leading Industrial Technology Award (independent development of Gen. 3 wheel bearing)
- 2004. 11.** Awarded the Export Tower of 100 Million
- 2005. 02.** Awarded the Daimler Chrysler '2004 Gold Award'
- 2006. 11.** Awarded the Export Tower of 200 Million
- 2007. 02.** Awarded "Quality 5 Star" of Beijing Hyundai Motor Co., Ltd
- 2008. 02.** won a prize from Minister of Commerce, Industry and Energy
- 2011. 11.** Awarded the Export Tower of 300 Million
- 2012. 01.** Awarded 'Quality 5 Star' from Hyundai-Kia Automotive Group
- 2012. 03.** Awarded Presidential Citation at the 46th Taxpayer's Day Ceremony
- 2013. 11.** Awarded Korea's Leading Industrial Technology Award (Development of Hybrid CABJ)
- 2013. 12.** Awarded the Export Tower of 400 Million
- 2015. 12.** Awarded the Export Tower of 500 Million
- 2016. 03.** Awarded the GM '2015 Supplier of the Year'
- 2016. 05.** Awarded the FORD 'World Excellence Awards' Silver Prize
- 2017. 03.** Awarded the GM '2016 Supplier of the Year'
- 2017. 05.** Awarded the Volvo 'Cost Performance Prize'
- 2017. 06.** Awarded the FCA 'Supplier of the Year'
- 2018. 04.** Awarded the GM '2017 Supplier of the Year'
- 2018. 04.** Awarded the FCA 'Supplier of the Year'
- 2018. 12.** Awarded the GM 'Innovation Supplier Award'

## VISION

Based on ILJIN core values; Innovation, Teamwork and Make It Happen, ILJIN's world-class approach actualizes the best customer values through fostering creative people, developing innovative technology, communication and cooperation.

ILJIN always aims to satisfy its customers.

# Aiming at the better future through challenge and innovation

We are taking a step forward to become a world-class corporation that actualizes the best customer values through fostering creative people, developing innovative technology, communication and cooperation.



### TEAMWORK

- Teamwork by which we strive together to achieve shared goals
- Share information among team members, departments and corporations
- Mutual effort and cooperation to achieve goals



### INNOVATION

- Creative activity to pioneer something different than present
- New ways of thinking and implementation for creative destruction
- Future-oriented mindset that is not satisfied with the current status



### MAKE IT HAPPEN

- Making the impossible possible with a sense of duty
- Facing challenges to meet the group's goal
- Service that satisfies customers

Innovation and make it happen  
**ILJIN**

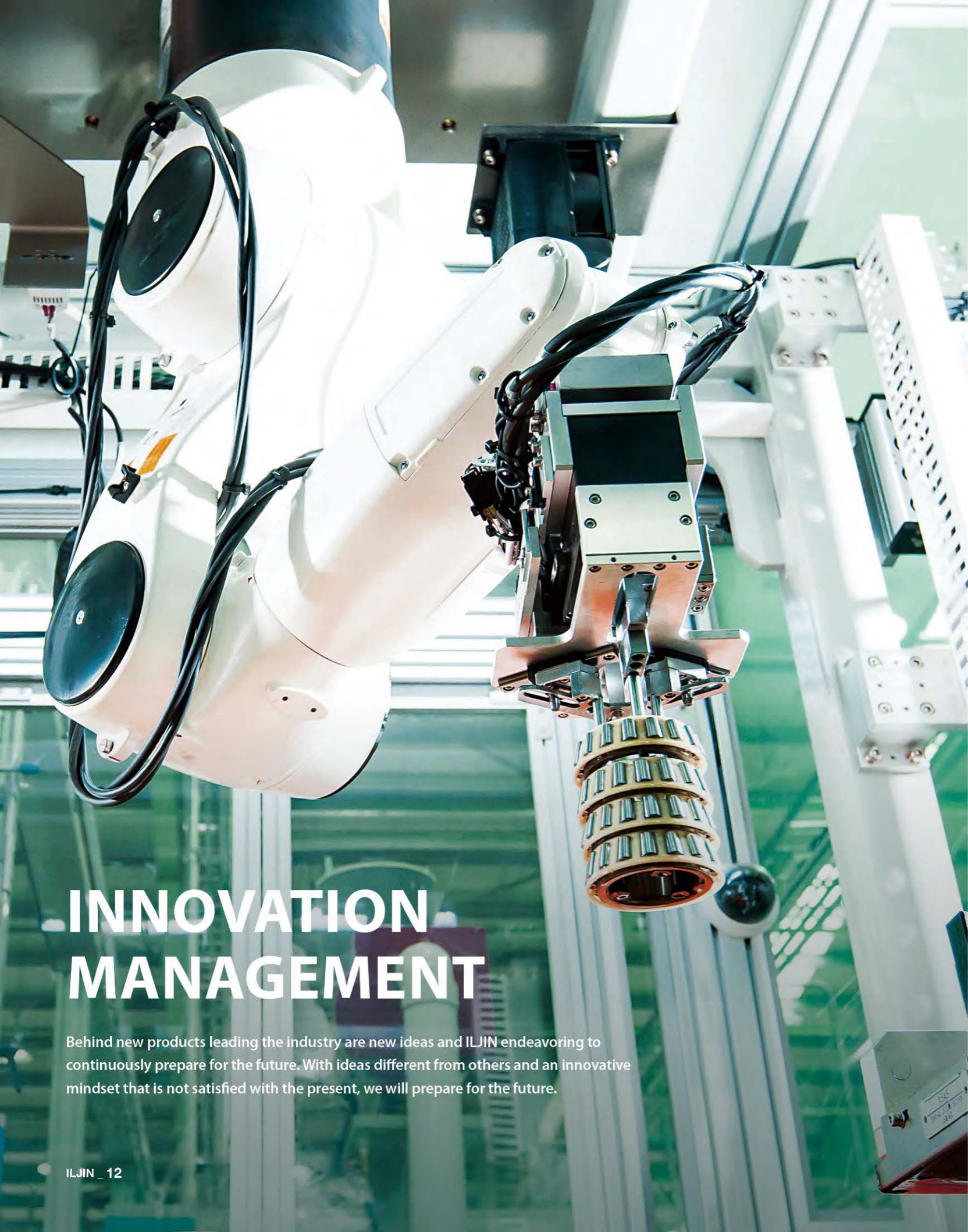

# INNOVATION MANAGEMENT

Behind new products leading the industry are new ideas and ILJIN endeavoring to continuously prepare for the future. With ideas different from others and an innovative mindset that is not satisfied with the present, we will prepare for the future.

## 6 INNOVATION

Our new future is rooted in Innovation. Breaking the old tradition and constructing new structures are the challenges ILJIN has been pursuing for the past half a century.

### Management Innovation

MI

To grow the corporation continuously and actively respond to the rapidly changing environment, we've innovated our corporation's management system (material management, cost management, sales management, finance management, production management, etc) to manage the corporation with structure and enhance its competitiveness.

FI

### Factory Innovation

Through automation, we produce competitive products by lowering costs and operating smart factory system by connecting all information collected from the field. This enables us to supply only the best products to our customers at the right moment.

SI

### Sales Innovation

We break away from the production-oriented structure of the past; now the sales department leads the research center and production, pioneers new products and new markets, and applies them to our mass production system. Sales always listens to our customers and tries hard to satisfy the customer's needs.

QI

### Quality Innovation

Customers around the world are receiving the best quality products no matter where they are.

PI

### Product Innovation

We've renovated the quality and function of existing products and have allocated company resources to research new products and develop innovative next-generation products.

OI

### Overseas Plant Innovation

ILJIN's plants operating around the world are producing the best quality products leading to customer satisfaction.

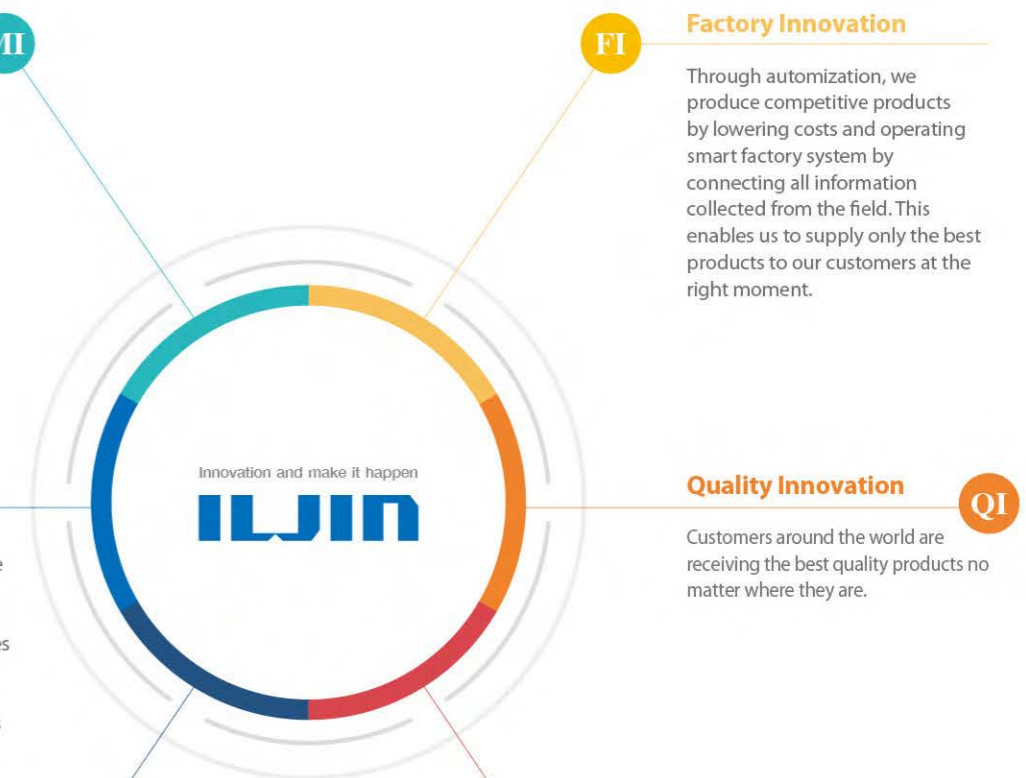

**Supplying  
Innovative Products  
with the Best Quality  
and Performance**

# **AUTOMOTIVE BUSINESS**

HUB UNIT  
BEARING

CHASSIS &  
SUSPENSION

POWERTRAIN

# Hub Unit Bearing

Attached to the wheel of vehicle, this bearing supports the weight while also transferring the power. There are two types, ball bearings and tapered roller bearings. Currently we are manufacturing all 1st, 2nd and 3rd generation bearings and 3 out of 10 cars worldwide are running with ILJIN's bearing.



## AUTOMOTIVE BUSINESS

### HUB UNIT BEARING

### CHASSIS & SUSPENSION

### POWERTRAIN

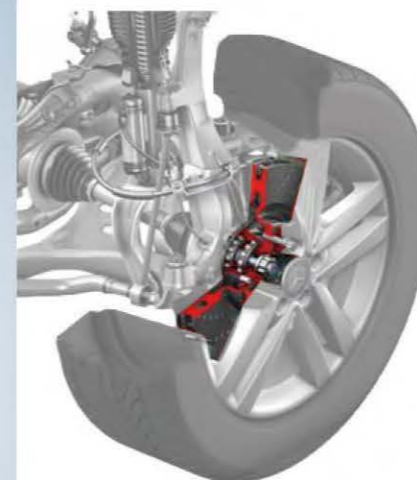

Hub Unit Bearing



Ball Bearing Gen.1

It has simpler assembly process and increased endurance level and reliability compared to those of Bearing Generation 0. Mainly used for driving wheels, it is composed of integrated outer ring, a two-piece inner ring, balls, seals, cages and grease.



Tapered Roller Bearing Gen.1

It has simple assembly process and higher endurance level and reliability through unitizing. Mainly used for heavier vehicles such as SUVs and pick-up Trucks, and applying a more compact design than ball bearings is possible.



Ball Bearing Gen.2

This bearing has a built-in hub unit which decreases the number of components and thus is made easier to assemble and have higher endurance and reliability. Mainly used for non-driven automotive applications, it is composed of an outer ring with a built-in integrated hub, two inner rings, balls, seats, cages and grease.



Tapered Roller Bearing Gen.2

Manufactured with an integrated built-in hub, its assembly process has been made easier and it has higher endurance and reliability. It is usually used for non-driven automobiles, it is for heavier vehicles and MPV automobiles.



Ball Bearing Gen.3

It has a hub made with an integral spline, so it improves ease of assembly. Increased durability and reliability. It is equipped with an ABS sensor and thus can be used for both driven and non-driven automobiles. It has integrated outer ring, inner ring integrated with hub, balls, seals, cages and grease.



Tapered Roller Bearing Gen.3

Its hub and splines are built-in, and has improved ease of assembly and increased durability and reliability. It is a bearing with an integrated hub that has improved the shortcomings of the 1st and 2nd generation bearing, and can be used for vehicles with various weights, including SUVs, Pick-up trucks and MPVs.

**AUTOMOTIVE  
BUSINESS**

HUB UNIT  
BEARING

CHASSIS &  
SUSPENSION

POWERTRAIN



This component connects the body of the automobile to its wheels and alleviates road impact transferred to the body by maintaining proper stiffness in all directions. It adjusts the movement of vehicle appropriately to enhance the passenger's comfort.



**Ball Joint**

This part acts as a joint and allows wheels to freely rotate and move up and down. It is attached to knuckles or arms.



**Stabilizer Link**

When cars go around a corner, this part increases stability when steering by minimizing the roll. It connects the stabilizer to knuckle, control arm or strut.



**Tie Rod End**

This acts as a link to steering gear and knuckle. It transfers the driver's steering movement to the front wheels. It maintains instant response through its high level of stiffness.



**Hybrid CABJ/Ball Joint**

By applying plastic injection molding technology to ball joints, we are able to stabilize the quality.



**Door Checker**

This part gives constant level of friction to the movement when opening and closing a door of a vehicle, thus allowing the door to feel appropriate level of movement feeling. It prevents accidents arising from doors automatically closing due to inclined roads or winds, acts as a primary stopper when opening a door and reduces the load applied to the hinge.



**Lower Control Arm**

Ball joints and control arms serve as a link to knuckle and cross member and help maintain the posture of a car.

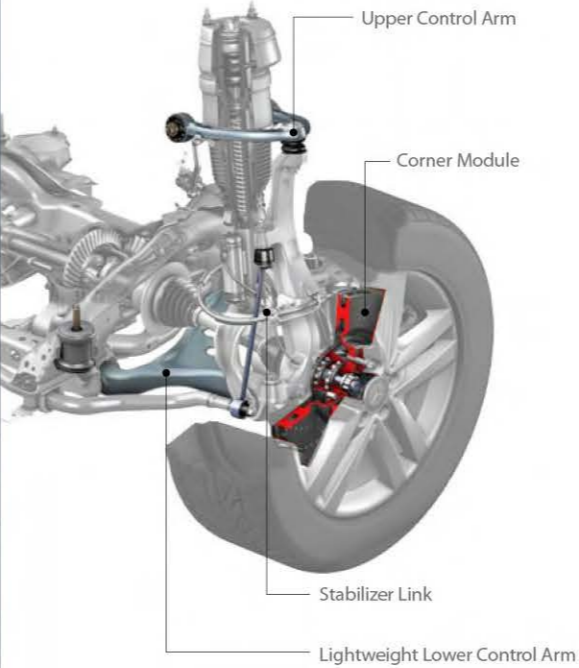

Upper Control Arm

Corner Module

Stabilizer Link

Lightweight Lower Control Arm



**Hybrid Upper Control Arm**

This part serves as a link to knuckle and cross member and helps maintain the posture of a car. It supports the weight of a vehicle and the impact load from the road surface.



**Corner Module**

It connects the arm and tire to support the weight of vehicle and transfers the movement of steering and driving force.

# POWERTRAIN

Bearings for transferring vehicles engine power support radial and axial loads from gears. With growing demand for better fuel efficiency, ILJIN focuses on developing bearings with low radial torque, and high wear resistance and rolling contact fatigue strength.



## AUTOMOTIVE BUSINESS

HUB UNIT BEARING

CHASSIS & SUSPENSION

POWERTRAIN



**Double Row Large Angular Contact Ball Bearing For Axles**

A bearing attached to shaft, a component of car axles and gear sets.



**Double Row Angular Contact Ball Bearing with Flange type**

A flanged typed ACBB bearing that attaches to automatic transmissions.



**Single Row Tapered Roller Bearing with a Steel Cage**

A tapered roller bearing that supports high radial and axial loads and lowered thermal radiation and wear by applying high-strength steel cage through design optimization.



**Single Row Tapered Roller Bearing with a Plastic Cage**

A low-torque tapered roller bearing that has lowered torque applied compared to that of existing steel cage by applying optimized designs to enhance lubrication performance.



**High Speed Deep Groove Ball Bearing**

A bearing used for precision machines with high speeds, precision measuring machines, high-speed motors, automotive T/M and axles and aerospace.



**Ball Ramp**

A bearing used for clutch application of vehicles. It transforms rotational motion to straight line motion and operates clutch.

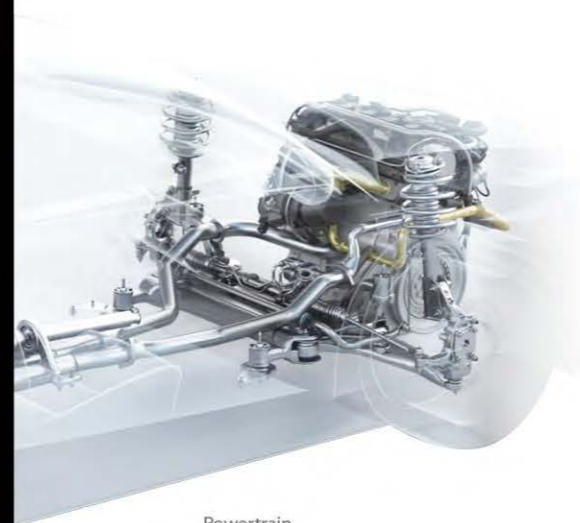

Powertrain

**Leading-edge  
Technology  
and Systematic  
Quality control**

**INDUSTRIAL  
BEARING**

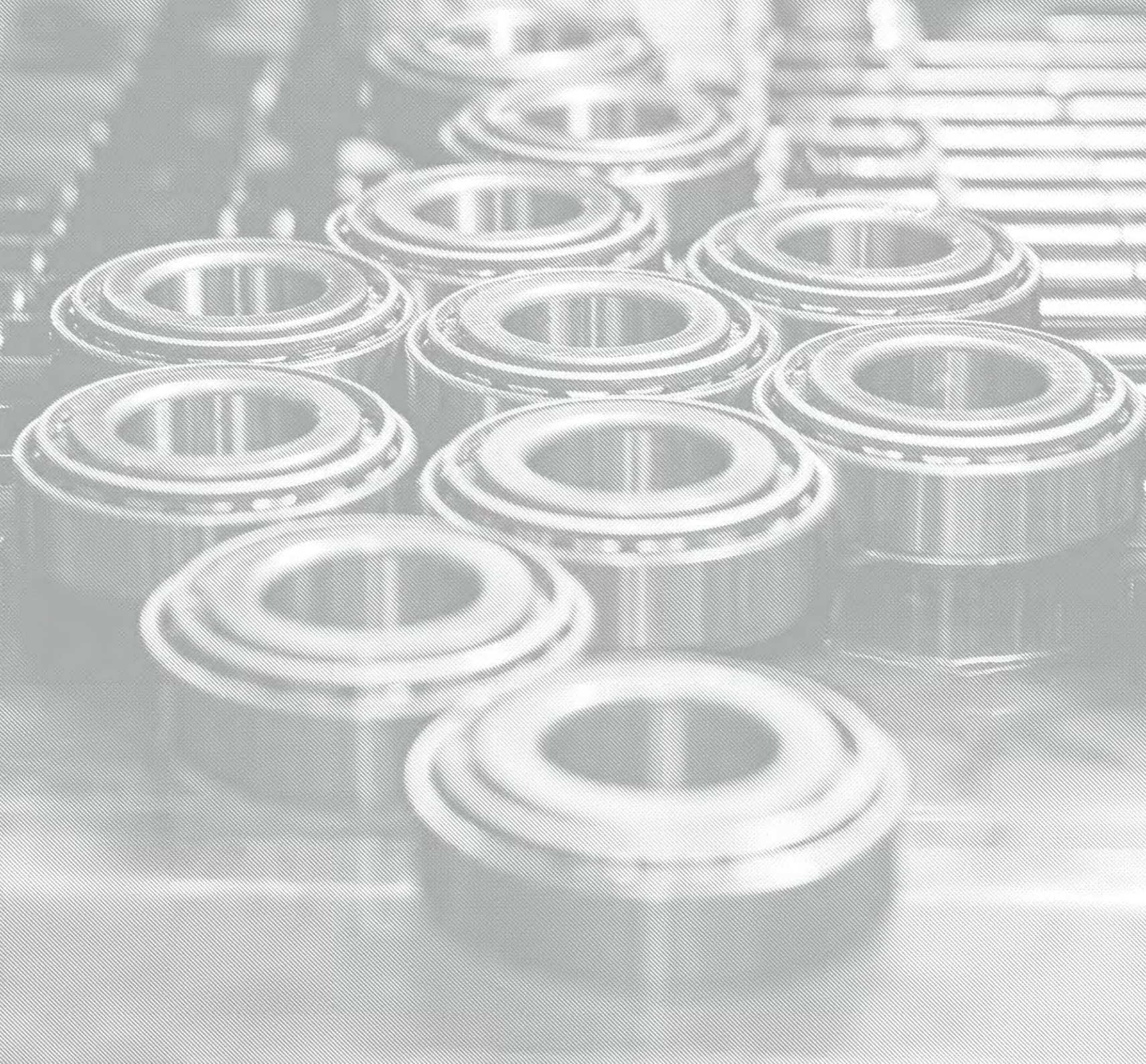

# INDUSTRIAL BEARING

Industrial bearing fixes axis of a rotating machine at a specific location. It supports the heavy load of a machine and displays high performance during high-speed rotation as well. It is used for construction machine, railway vehicles, wind generators and robots.

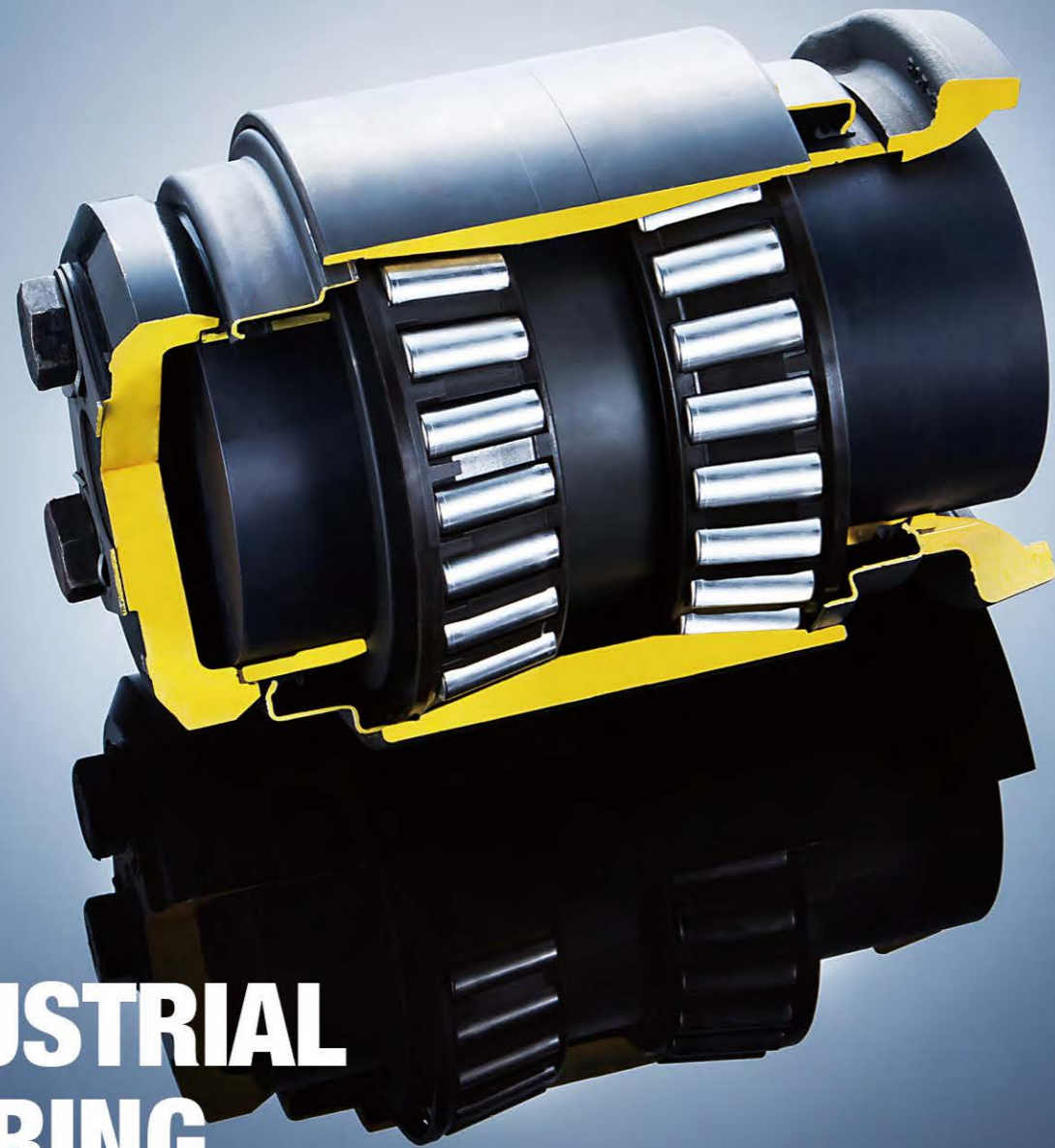

## INDUSTRIAL BEARING



Railway



**Railway Axle Bearing(TRB)**

This is a sealed double row tapered roller bearing used as an axle bearing for freight railroad cars and high-speed trains.



**Railway Axle Bearing(CRB)**

This is a double row cylindrical roller bearing used as an axle bearing for metro, electric trains and light rail vehicles.



Robot



**Cross Roller Bearing**

This is a high precision crossed roller bearing is used in numerous areas including robot arms, motors, machine tools and medical devices.



Construction Equipment



**Large Angular Contact Ball Bearing**

This is an angular contact bearing with sizes bigger than regular ball bearing used for deriving/swivel reducer of industrial vehicles and robot arm reducers.



**TRB For Tunnel Boring Machine(TBM)**

This is a bearing used for cutter rings of tunnel boring machines.



Wind Turbine



**Slewing Bearing(Yaw Bearing)**

Yaw bearings are placed between the upper part and lower part of large industrial machines. It allows the machine to rotate according to the axial and moment loads.



**Slewing Bearing(Pitch Bearing)**

Pitch Bearings have the ability to adjust the wings' angles according to the wind speed.

## RESEARCH DEVELOPMENT

Throughout the world, ILJIN has secured state-of-the-art research machines to enable ILJIN's branches to conduct internal quality testing, to continuously communicate with its customers at their closest locations, provide instant feedback on the work currently in progress, and educate customers about new products. We are striving to become the world's best company that provides most competitive products by increasing R&D activities.



### R&D Vision

Through investing in human resources and technical cooperation with other world-class companies, ILJIN is actualizing future technologies. ILJIN researcher's passion toward research and development is the basis that realizes the vision of being a "Technology Leader who creates the future" and enables the ILJIN Group to become the global leader of bearing manufacturing.

## Product Innovation

ILJIN has been investing not only in improving the performance of existing products, but also in opening up future markets. Our wheel bearing research centers have been focusing on bearing technology for electric cars and autonomous cars. ILJIN has been developing new innovative products and bearings with advanced technology that goes along with the current trend of light-weights.



## Global R&D Network

ILJIN's Seoul R&D center manages the overall operation of global R&D in the United States and Europe; each responsible for supporting its direct region. ILJIN has placed machines for product testing in all of its branches to not only develop new products, but also identify the needs of customers around the world and respond to markets that are changing every moment. ILJIN's R&D network, is prepared to respond to the needs of our customers 24/7, and is pursuing customer satisfaction with the goal to achieve best performance and uniform quality.



USA R&D Center Test Room



Industrial Bearing Test Room



Hub Unit Bearing Test Room



Chassis & Suspension Test Room

**CORPORATE  
SOCIAL  
RESPONSIBILITY**

For a long time ILJIN grew through customer needs only. Now with the idea of mutual growth, ILJIN practices the act of sharing and cooperation. Operating under the belief that true growth comes through growth as a community, ILJIN stands by its neighbors to progress further and longer.



**Growth together**

Under its slogan "the joy of sharing makes the world even more beautiful", ILJIN has been creating sustainable future values. ILJIN carries out environmental cleanliness, local residential environment improvement and also nurturing future science leaders which are parts of corporate social responsibility.



# GLOBAL NETWORKS

ILJIN's headquarter is located in Seoul. Corporations in Jecheon, Yeongju, Gyeongju, Yeongwol are manufacturing products and supplying them to customers. There are 4 corporations and 12 factories in Korea.



**HEADQUARTERS**  
527 Samseong-ro Gangnam-gu(Zip code: 06157)  
TEL. 82-2-553-1795  
FAX. 82-2-566-5621, 82-2-553-1799

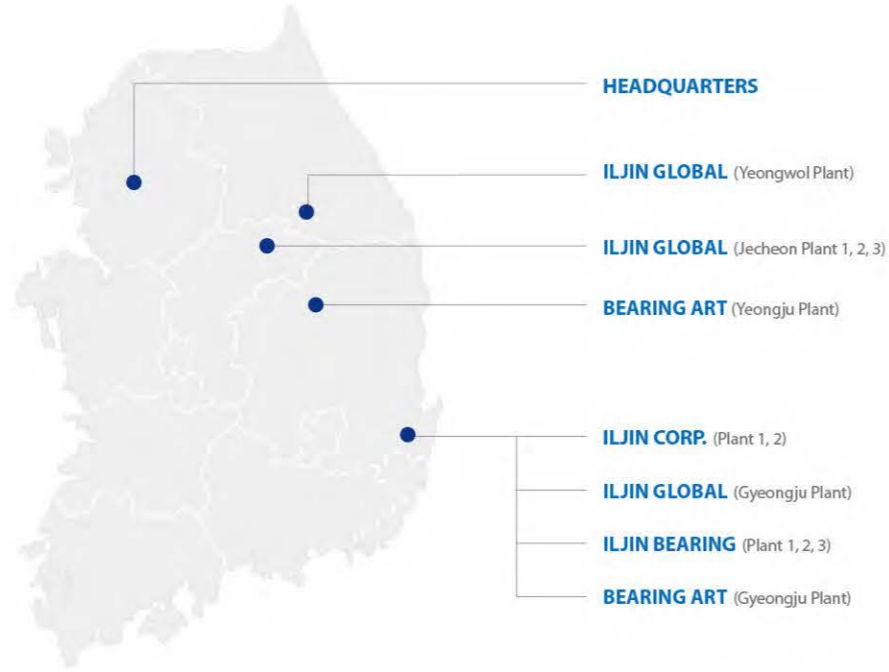

**ILJIN GLOBAL(Jecheon Plant 1)**  
16 Bio Valley 1-ro, Jecheon-si, Chungcheongbuk-do(Zip Code 27159)  
TEL. 82-43-652-8711  
FAX. 82-43-652-6644



**BEARING ART(Yeongju Plant)**  
105, Bangu-ro, Jangsu-myeon, Yeongju-si, Gyeongsangbuk-do (Zip Code 36145)  
TEL. 82-70-4161-5000 / FAX. 82-54-631-8713



**ILJIN GLOBAL(Jecheon Plant 2)**  
165 Hanbang Expo-ro, Bongyang-eup, Jecheon-si, Chungcheongbuk-do(Zip Code 27116)  
TEL. 82-43-652-8711  
FAX. 82-43-652-6644



**ILJIN GLOBAL(Jecheon Plant 3)**  
170, Hanbang expo-ro, Jecheon-si, Chungcheongbuk-do(Zip Code 27116)  
TEL. 82-43-652-8711  
FAX. 82-43-652-6644



**ILJIN GLOBAL(Yeongwol Plant)**  
241 Bamjae-ro, Yeongwol-gun, Gangwon-do(Zip Code 26209)  
TEL. 82-33-372-9851  
FAX. 82-33-372-9849



**ILJIN GLOBAL(Gyeongju Plant)**  
310 Anhyeon-ro, Hyeongok-myeon, Gyeongju-si, Gyeongsangbuk-do(Zip Code 38046)  
TEL. 82-54-770-8986  
FAX. 82-54-770-7639



**ILJIN BEARING(Plant 1)**  
4419 Saneop-ro, Gyeongju-si, Gyeongsangbuk-do(Zip Code 38071)  
TEL. 82-54-770-5555  
FAX. 82-54-770-5549



**ILJIN BEARING(Plant 2)**  
70 Gongdan-ro, Gyeongju-si, Gyeongsangbuk-do(Zip Code 38075)  
TEL. 82-54-770-5555  
FAX. 82-54-770-5549



**ILJIN BEARING(Plant 3)**  
85 Gongdan-ro, Gyeongju-si, Gyeongsangbuk-do(Zip Code 38071)  
TEL. 82-54-770-5555  
FAX. 82-54-770-5549



**ILJIN CORP. (Plant 1)**  
45 Yurim-ro 13-gil, Gyeongju-si, Gyeongsangbuk-do(Zip Code 38073)  
TEL. 82-54-770-7500  
FAX. 82-54-770-7579



**ILJIN CORP. (Plant 2)**  
247-80 Hwasangongdan-gil, Cheonbuk-myeon, Gyeongju-si, Gyeongsangbuk-do(Zip Code 38034)  
TEL. 82-54-770-7500  
FAX. 82-54-770-7579



**BEARING ART(Gyeongju Plant)**  
310 Anhyeon-ro, Hyeongok-myeon, Gyeongju-si, Gyeongsangbuk-do(Zip Code 38046)  
TEL. 82-70-4161-5000  
FAX. 82-54-631-8713

# GLOBAL NETWORKS

ILJIN has 9 manufacturing corporations, 2 sales corporations and 6 sales branches in overseas.  
Overseas corporations are operated under systemized management in order to ensure the same quality product as those produced in Korea and are providing services to customers at a close distance to enable immediate response to their needs.



**BEIJING ILJIN**  
Xinggu Industrial Zone Pinggu, Beijing, China  
TEL. 86-10-6995-0789  
FAX. 86-10-6995-0689



**TIANJIN ILJIN(1st Plant)**  
No. 12. Quan Da Road Wuqing Development Area, Tianjin, China  
TEL. 86-22-8217-8773 / FAX. 86-22-8217-0213



**TIANJIN ILJIN(2nd Plant)**  
No. 16. Xin Ping Road Wuqing Development Area, Tianjin, China  
TEL. 86-22-8295-5002 / FAX. 86-22-8295-5025



**JIANGSU ILJIN**  
51 Lao Shan Rd. Yancheng, Jiangsu, 224007, China  
TEL. 86-515-8902-5201  
FAX. 86-515-8899-9050



**CHONGQING ILJIN**  
#1235 Mingtao 1 Rd Changshou District, Chongqing, China  
TEL. 86-70-4436-6578



**ILJIN GLOBAL INDIA**  
Plot No.-A2, Phase-II, Khandala MIDC, Kesurdi, Tal- Khandala, Dist- Satara - 412802, Maharashtra, India  
TEL. 91-20-4124-4059



**ILJIN INDIA**  
B1&B2 Sipcot Industrial Park, Irrungattukottal, Sriperumbudur Kacheeparam dist, Chennai, Tamil Nadu-602 105, India  
TEL. 91-4111-56022~5  
FAX. 86-10-6995-91-4111-56021



**ILJIN USA - Michigan**  
28055 Haggerty Rd. Novi, MI 48377-2902, USA  
TEL. 1-334-297-4494  
FAX. 1-248-848-0566



**ILJIN USA - South Carolina**  
1705 Poplar Drive Extension Greer, South Carolina 29651-6518, USA  
TEL. 1-864-848-4801  
FAX. 1-864-848-4811



**ILJIN ALABAMA**  
14 Downing Drive, Phenix City, AL 36869, USA  
TEL. 1-334-297-4494  
FAX. 1-334-297-4122



**ILJIN SLOVAKIA**  
972 16 Pravenec 422, Slovakia  
TEL. 421-46-544-1070~1  
FAX. 421-46-544-1073



**ILJIN BEARING GmbH**  
Amsterdam Str. 2, 97424 Schweinfurt, Germany  
TEL. 49-9721-97797-10  
FAX. 49-9721-97797-59

**BEIJING(China) Sales Branch**  
100102 Room 2710, Fangheng Guoji A bldg, No. 6 Futong Dong Dajie, Wangjing, Chaoyang District, Beijing, China

**SHANGHAI(China) Sales Branch**  
Room2302, Hongjia Tower, No.388 Fushan Road, Pudong New Area, Shanghai, China

**PUNE(India) Sales Branch**  
Office No.204&2015 Mont-Vert Marc Servey No.129/2 Pashan Sus Road Pune Maharashtra, India

**YOKOHAMA(Japan) Sales Branch**  
222-0033 Shin-yokohama Koshin Bldg. 4F Shin-yokohama 2-12-1 Kohoku-ku Yokohama-shi Kanagawa-ken, Japan

**TURIN(Italy) Sales Branch**  
Via Livorno 60 10144 Torino, Italy

**PARIS(France) Sales Branch**  
7 Parc ariane - Immeuble Mars 7 boulevard des chenes 78280 Guyancourt, France

# Developing New Growth Driver

---

## Now ILJIN advances to a world-class level

Customer satisfaction is ILJIN's foremost priority.

Better products. Better service. Better systems. Better technology.

To achieve these, ILJIN thinks one more time for the best and takes one step higher for perfection.

**ILJIN**